

Indeterminate-Agreement: Some Consequences for the Case System*

Ken Hiraiwa
JSPS Research Fellow/University of Tokyo

August 11, 2005

Abstract

This paper, building on a close scrutiny of Raising-to-Object constructions in Japanese, demonstrates that Kishimoto's (2001) generalizations that (i) the distribution of indeterminates in Japanese is determined by LF configuration and that (ii) Case is a property of LF configuration are both empirically incorrect. On the contrary, I demonstrate that the indeterminates must be licensed at the point of Transfer and that structural Case is a property of action at a distance –Agree. The behavior of indeterminates reveals that the derivation of Raising-to-Object in Japanese is a two-step process: raising to the edge of “VP” via [Spec, CP] and then (optionally) to the edge of v^*P . Finally, I examine varieties of raising constructions, using the Indeterminate-Agreement as a syntactic diagnostic test for the presence/absence of overt raising in an SOV language where it is usually very hard to find a way to detect movement.

1 Introduction

Kishimoto (2001) makes important observations on the behavior of the so-called indeterminates in Japanese (cf. Kuroda 1965, McGloin 1976, Muraki 1978, Kishimoto 2001, Takahashi 2002, Hiraiwa 2002b among others) and their theoretical implications for Japanese syntax. Kishimoto (2001) claims that the behavior of indeterminates reveals that structural

*I am grateful to Noam Chomsky, Chris Collins, Danny Fox, Ken Hale, Nobuko Hasegawa, Sachiko Kato, Hideki Kishimoto, Sachie Kotani, Howard Lasnik, Alec Marantz, Ken-ichi Mihara, Shigeru Miyagawa, David Pesetsky, Norvin Richards, Luigi Rizzi, Koji Sugisaki, Shoichi Takahashi, Yuji Takano, Akira Watanabe, and in particular Susumu Kuno for helpful comments and discussions. Special thanks go to Justin Fitzpatrick and Joey Sabbagh, who carefully read a draft. An earlier version of this paper was accepted for WCCFL 21 but never published. Portions of this paper have been presented at MIT (March 2001), Harvard University (April 2001), and Osaka University of Foreign Studies (June 2001). This research is partially supported by the Grant-in-Aid for JSPS Research Fellows 1710271 from the Japan Society for the Promotion of Science (JSPS).

Case in Japanese must be determined by LF configurations, returning back to the Spec-Head Agreement in Chomsky (1995). Although illuminating, I will show that Kishimoto’s (2001) empirical generalization misses one crucial fact; namely, the Raising-to-Object constructions (RTO) in Japanese. Contrary to Kishimoto’s claim, I will demonstrate that a closer examination reveals that structural Case in Japanese is licensed via a universal mechanism called *Agree* (Chomsky 2000, 2001) and that a simpler solution is available to the workings of the syntax of the indeterminate pronouns, which I term *Indeterminate-Agreement*.

It is now well-known that many languages of the world allow RTO across a finite/tensed CP boundary (e.g. Japanese, (varieties of) Quechua (Lefebvre and Muysken 1988), Malagasy, Moroccan Arabic, Kikuyu, Persian, Korean, etc.; see Massam 1985, Ura 1994, Bruening 2001 among others) in contrast with English (cf. Rosenbaum 1967, Postal 1974). This type of language often allows a null pronoun, and hence raises a non-trivial question as to whether the RTO is “raising” (1a), “prolepsis/control” (1b), or something else “Agree”/ECM (1c).

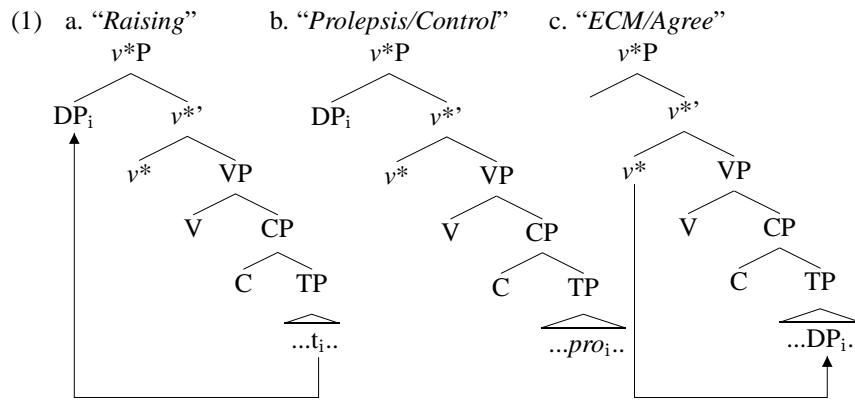

Cuzco Quechua, for example, provides convincing evidence for raising. (2a) shows that the embedded subject DP is Case-marked genitive. The ECMed DP in (2b), on the other hand, takes accusative Case in addition to genitive Case assigned in the embedded clause.¹ Furthermore, the ECMed subject DP must precede the matrix verb. The “double” Case-marking, in conjunction with the word order permutation, explicitly excludes the prolepsis/control analysis.

- (2) Cuzco Quechua: (Lefebvre and Muysken 1988, 144, Claire. Lefebvre p.c.)
- a. Maryyacha numa-n **Xwancha-q*(-ta)** platanu ranti-na-n-ta.
 Maria want-3 Juan-Gen-Acc banana exchange-Nml-3-Acc
 ‘Maria wants Juan to buy bananas.’
 - b. Maryyacha **Xwancha-q*(-ta)**_i numa-n t_i platanu ranti-na-n]-ta.
 Maria Juan-Gen-Acc want-3 banana exchange-Nml-3-Acc

¹For mechanisms of genitive Case-marking, see Lefebvre and Muysken (1988) and Hiraiwa (2001, 2005). I am grateful to Claire Lefebvre for her kind help with confirming the Cuzco Quechua data. All errors are my own.

‘Maria wants Juan to buy bananas.’

Unfortunately, such evidence is hard to obtain in Japanese. Kuno (1972, 1976) presents word order evidence for a raising-to-object operation. Notice that nominative or topicalized embedded subject DPs cannot precede a matrix adverb, whereas ECMed subject DPs optionally can.

(3) Japanese:

- a. Taro-wa (orokanimo) **Hanako-ga/wa** (*orokanimo) baka da to
Taro-Top stupidly Hanako-Nom/Top stupidly stupid Cpl.Prs C
omot-ta.
think-Pst
‘(Stupidly,) Taro considered Hanako to be stupid.’
- b. Taro-wa (orokanimo) **Hanako-wo**_i (orokanimo) baka da to omot-ta.
Taro-Top stupidly Hanako-Acc stupidly stupid Cpl.Prs C think-Pst
‘(Stupidly,) Taro considered Hanako to be stupid.’

This simple fact convincingly shows that in Japanese, the position below matrix subjects and above matrix adverbs is available only for ECMed accusative DPs, but not for nominative/topicalized DPs. Contrary to Kuno’s claim (Kuno 1976), however, the word order evidence does not convince us that (3b) involves “raising” as in (1a); a “prolepsis/control” analysis (1b) (Saito 1985, Oka 1988, Hoji 1991, Takano 2003) also expects the asymmetry in (3). In fact, for this reason, there has been much controversy since the 1970’s about the structure of sentences like (3b).

This paper, based on *Indeterminate-Agreement* constructions, will add another piece of evidence for adopting the raising structure (1a) to (3b) (Kuno 1976, Ura 1994, Sakai 1998 and against assigning the prolepsis/control analysis (1b); Saito 1985, Hoji 1991). More importantly, I will argue that the RTO in Japanese is founded on long-distance agreement as in (1c). I will show that Indeterminate-Agreement also reveals that syntactic raising into the matrix position is optional in RTO (cf. Lasnik 1999 for English) and is a two-step process, targeting the edges of “VP” and *v**P, successive-cyclically.

The organization of this paper is as follows: Section 2 investigates properties of Indeterminate-Agreement. I critically review Kishimoto (2001) and propose an articulated theory of the phenomenon. Section 3 re-examines RTO, applying Indeterminate-Agreement to the construction. Section 4 proposes a *v**-Aspect theory of RTO building on the C-T theory of nominative/genitive Case valuation proposed in Hiraiwa (2005). Section 5 discusses implications of Indeterminate-Agreement for varieties of raising constructions. Section 6 is a summary.

2 Indeterminate Agreement

As first observed in Kuroda (1965), an indeterminate NP forms a Negative Polarity Item (NPI) or a universal quantifier, when it is combined with the quantificational particle *-mo* (see also McGloin 1976, Muraki 1978, Nishigauchi 1990, Hiraiwa 2002b, Kishimoto 2001, Takahashi 2002). The same indeterminates are interpreted as existential, when they are combined with the question particle *-ka*.

- (4) Japanese:
- a. dare, nani
Indet(human), Indet(inanimate)
'who, what'
 - b. dare-**mo**, nani-**mo**
Indet(human)-Q, Indet(inanimate)-Q
'everyone/any one, everything/anything'
 - c. dare-**ka**, nani-**ka**
Indet(human)-Q, Indet(inanimate)-Q
'someone, something'

The indeterminate plus the particle *-mo* can be interpreted as either an NPI or a universal quantifier, which is reflected in the tonal pattern and the (in)compatibility with Case-markers. The capital letter indicates a high pitch accent/tone.

- (5) Japanese:
- a. **DARE-mo-ga** ki-ta.
Indet-Q-Nom come-Pst
'Everyone came.'
 - b. **daRE-MO(-*ga)** ko-nakat-ta.
Indet-Q-Nom come-Neg-Pst
'No one came.'

Significantly, Kuroda (1965) observes that an indeterminate can be structurally split from *-mo*. In (6a) the NPI item *indeterminate+mo* as a unit is the object of the verb. In (6b), on the other hand, the indeterminate alone is the object of the verb *seme-ru* "blame" and the Q-particle is attached to the verb head *v**. In this case, tense is left behind and saved by a process similar to *do*-support in English, as indicated by the obligatory insertion of the *sur* light verb.

- (6) Japanese:
- a. Taro-wa [_{v*P} **dare-mo** seme]-nakat-ta.
Taro-Top Indet-Q blame-Neg-Pst
'Taro didn't blame anyone.'
 - b. Taro-wa [_{v*P} **dare-wo** seme]-**mo** si-nakat-ta.
Taro-Top Indet-Acc blame(Inf)-Q do-Neg-Pst
'Taro didn't blame anyone.'

(7) illustrates examples of "Indeterminate-Q splitting" in DP, *v*P* and Complex DP, respectively. In (7a), the indeterminate is the possessor of the noun *hon* "book" and the Q-particle *-mo* attaches to the head of the noun phrase (perhaps D). In (7b), the Q-particle is attached to the causative verb and dominates the indeterminate object. And finally, (7c) is a case where the subject of the relative clause is an indeterminate and the Q-particle is attached

to the head of the complex DP. I will term the split quantification phenomena *Indeterminate-Agreement*.^{2,3}

(7) Japanese:

- a. Taro-wa [_{DP} **dare-no** hon]-**mo** yoma-nakat-ta.
Taro-Top Indet-Gen book-Q read-Neg-Pst
'Taro didn't read anyone's book.'
- b. Taro-wa [_{V*P} **dare-ni** sono-ronbun-wo yom-ase]-**mo** si-nakat-ta.
Taro-Top Indet-Dat the-paper-Acc read-Caus-Q do-Neg-Pst
'Taro didn't allow anyone to read the paper.'
- c. Taro-wa [_{CP} **dare-ga** kai-ta ronbun]-**mo** yoma-nakat-ta.
Taro-Top Indet-Nom write-Pst paper-Q read-Neg-Pst
'Taro didn't read any paper that anyone wrote.'

But the splitting does not come free; it is subject to a c-command condition. An indeterminate NP must be in the c-command domain of the Q-particle *-mo* (henceforth *cd(Q)*). I will assume that Q-particles adjoin to heads. Consider (9).

(8) Indeterminates must be in *cdQ*.

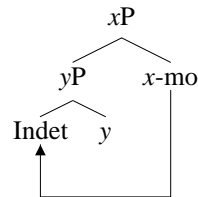

All the examples above meet this condition. Notice, however, that in the following examples, indeterminates cannot be licensed.

(9) Japanese:

- a. **Dare-mo**_i [_{V*P} t_i Hanako-wo seme]-nakat-ta.
Indet-Q Hanako-Acc blame-Neg-Pst
'No one blamed Hanako.'

²Takahashi (2002) calls this *D-Raising* and Kishimoto (2001) calls it *Indeterminate Pronoun Binding*. Since, as Takahashi (2002) argues and we will also see, there is good evidence to think that the construction in question does not involve binding, I will reject Kishimoto's terminology. See also Takahashi (2002) for some arguments against binding. Takahashi (2002) proposes a D-Raising analysis, whereby the determiner *-mo* starts out within the indeterminate and raises to higher positions, along the lines of Hagstrom (1998). I will not discuss issues raised by his analysis here. Also, I will discuss the non-NPI use of the indeterminates, because there are certain syntactic differences between the two uses of the indeterminates; see Takahashi 2002.

³The indeterminate-Q splitting requires a formation of a certain kind of phonological phrasing, usually involving de-accenting after the indeterminate until the Q-particle *-mo*. One should not be confused and think that the phonological phrasing is the main factor determining the licensing of the indeterminates in this construction. As it will become clear later, the mechanism of the Indeterminate-Agreement is syntactic.

- b. * **Dare-ga** [_{DP} Hanako-no hon-**mo**] yoma-nakat-ta.
 Indet-Nom Hanako-Gen book-Q read-Neg-Pst
 ‘No one read Hanako’s book.’
- c. * **Dare-ga**_i [_{v*P} t_i Hanako-wo seme]-**mo** si-nakat-ta.
 Indet-Nom Hanako-Acc blame(Inf)-Q do-Neg-Pst
 ‘No one blamed Hanako.’

In (9b), there is no way for the Q-particle to c-command the indeterminate subject. Likewise, (9c) is ungrammatical because the indeterminate subject in [Spec, TP] is out of the c-command domain of the Q-particle attached to the v*.

(10) A Subject Indeterminate (=9c)

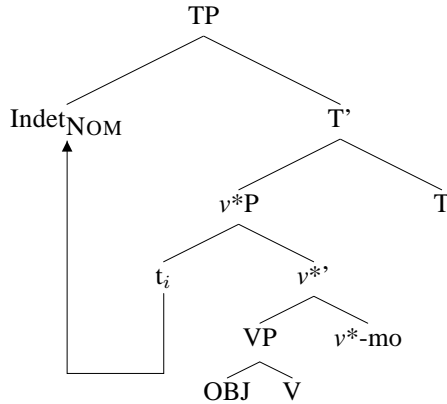

2.1 Kishimoto (2001)

In certain stative constructions, the object can be marked Nominative in Japanese, manifesting the so-called Nominative Object constructions as in (11). Kishimoto (2001) further observes that nominative indeterminate objects cannot be licensed by *-mo* attached to v* as shown in (11b).

(11) Japanese:

- a. Taro-wa **sono-uta-ga/-wo** uta-e-na-i.
 Taro-Top the-song-Nom/-Acc sing-can-Neg-Prs
 ‘Taro cannot sing the song.’
- b. Taro-wa [**nani-*ga**^{o.k.} -**wo** uta-e-mo] si-na-i.
 Taro-Top Indet-Nom/-Acc sing-can-Q do-Neg-Prs
 ‘Taro cannot sing anything.’ (Kishimoto 2001, 606; slightly modified)

Based on these observations, he argues that the fact that (12) shows Proper Binding Condition effects indicates that the nominative object remains within the v*P, as the accusative object does.

(12) Japanese:

* [v^*P uta-e-mo] Taro-wa sono-uta-ga/-wo si-nakat-ta.
 sing-can-Q Taro-wa the-song-Nom/-Acc do-Neg-Pst

‘Taro cannot even sing the song.’ (Kishimoto 2001, 606; slightly modified)

He proposes the following as a mechanism of indeterminates.

(13) Indeterminate Pronoun Binding (Kishimoto 2001, 601)

Y is in the domain of a head X if it is contained in $Max(X)$, where $Max(X)$ is the least full-category maximal projection dominating X.

(13) amounts to saying that indeterminates must be “m”-commanded by a Q-particle. It is puzzling for him, however, that the nominative indeterminate object cannot be licensed by the Q-particle on v^* , even though it is m-commanded on the surface. Thus, he goes further and takes this to be the evidence that Case is checked at LF via covert Spec-Head Agreement (Chomsky 1993) and that Indeterminate-Agreement –*Indeterminate Pronoun Binding*, in his terms – is sensitive to the condition (13) at LF. Thus, according to this theory, the derivation (11b) is ungrammatical since the nominative object undergoes LF-movement to [Spec, TP], escaping out of the m-command domain of the Q-particle on v^* .

(14) Indeterminate Nominative Object at LF

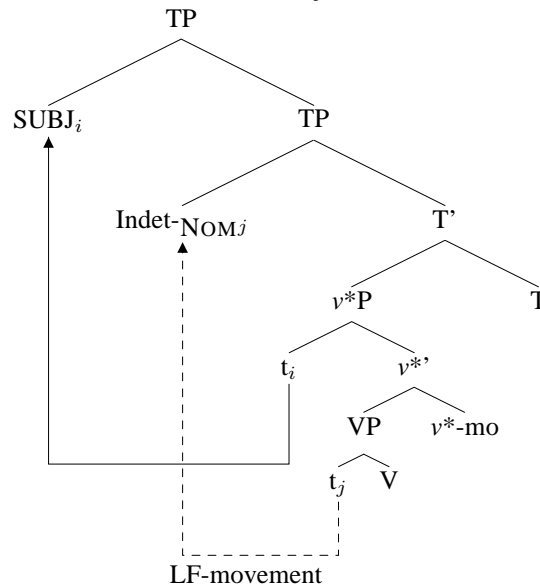

At LF, the nominative object has to be raised to [Spec, v^*P] to have its Case checked by v^* . Hence the nominative object is out of the domain of *-mo* at LF and the indeterminate cannot be bound.

2.2 A Refinement

Setting aside empirical problems for the moment (we will return to them shortly in the next section), the proposal has two conceptual problems.

First, it assumes that Case-licensing involves an LF configuration –namely, an LF Spec-Head relation (Chomsky 1993). This assumption has been challenged and much counter-evidence has been accumulated together with the rejection of the distinction of overt/covert syntax, as far as Case and Agreement are concerned. Second, it refers to *m*-command as stated in (13). The notion of Spec-Head Agreement also presupposes *m*-command. All of the phenomena that have been captured in terms of *m*-command have been re-examined – successfully, in my eyes– in terms of the more natural conception: *c*-command.

I will pursue, therefore, a more natural hypothesis for Indeterminate-Agreement: the indeterminate must be in the *c*-command domain of the Q-particle.

(15) The head of the chain of the indeterminate must be in *cd*(Q) at Transfer.⁴

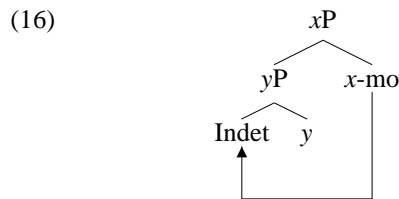

The hypothesis (15) is free from the two conceptual problems that Kishimoto’s theory suffers. In the section that follows, I will demonstrate that (15) in fact attains higher empirical adequacy, which Kishimoto’s LF Case hypothesis cannot achieve.

3 Raising-to-Object

3.1 Indeterminate-Agreement and Raising-to-Object

As first observed by Sakai (1998), Indeterminate-Agreement is also grammatical with CP clauses. Thus the Q-particle *-mo* can attach to the whole CP clause and bind an element within it, as shown in (17)

(17) Japanese:

Taro-wa [_{CP} **dare-ga** baka da to]-**mo** omowa-nakat-ta.
 Taro-Top Indet-Nom stupid Cpl C-Q think-Neg-Pst

‘Taro didn’t consider anyone to be stupid.’

⁴Transfer sends out a syntactic object to the interfaces and takes place cyclically at each phase level. See Chomsky (2000, 2001, 2004).

Significantly, Indeterminate-Agreement is licit with RTO as well. In (18), the embedded subject is marked Accusative just as in ECM constructions in English. This construction has been considered to be a case of RTO/ECM in Japanese (Kuno 1976).⁵

(18) Japanese:

Taro-wa **dare(-no-koto)-wo** baka da to-**mo** omowa-nakat-ta.
 Taro-Top Indet(-Gen-thing)-Acc stupid Cpl C-Q think-Neg-Pst

‘Taro didn’t consider anyone to be stupid.’ (cf. Sakai 1998)

Consider (19) and (20). Indeterminate-Agreement is licensed with the indeterminate ECMed subject when there is no intervening matrix adverb or a subject-oriented floating quantifier (see (19b)/(19c) and (20b)/(20c)). However, if the ECMed indeterminate NP is overtly raised in front of the matrix adverb or the subject-oriented floating quantifier, then Indeterminate-Agreement is blocked and the sentence results in ungrammaticality, as shown in (19d) and (20d).

(19) Japanese:

- a. karera-wa zen-in Taro(-no-koto)-wo baka da to omowa-nakat-ta.
 they-Top all Taro(-Gen-thing)-Acc stupid Cpl C think-Neg-Pst
 ‘All of them didn’t consider Taro to be stupid.’
- b. karera-wa Taro(-no-koto)-wo zen-in baka da to omowa-nakat-ta.
 they-Top Taro(-Gen-thing)-Acc all stupid Cpl C think-Neg-Pst
 ‘All of them didn’t consider Taro to be stupid.’
- c. karera-wa zen-in **dare(-no-koto)-wo** baka da to-**mo** omowa-nakat-ta.
 they-Top all Indet(-Gen-thing)-Acc stupid Cpl C-Q think-Neg-Pst
 ‘All of them didn’t consider Taro to be stupid.’
- d. * karera-wa **dare(-no-koto)-wo_i** zen-in t_i baka da to-**mo** omowa-nakat-ta.
 they-Top Indet(-Gen-thing)-Acc all stupid Cpl C-Q think-Neg-Pst
 ‘All of them didn’t consider anyone to be stupid.’

(20) Japanese:

- a. Taro-wa orokanimo Hanako(-no-koto)-wo baka da to omowa-nakat-ta.
 Taro-Top stupidly Hanako(-Gen-thing)-Acc stupid Cpl C think-Neg-Pst
 ‘Stupidly, Taro didn’t consider Hanako to be stupid.’
- b. Taro-wa Hanako(-no-koto)-wo orokanimo baka da to omowa-nakat-ta.
 Taro-Top Hanako(-Gen-thing)-Acc stupidly stupid Cpl C think-Neg-Pst
 ‘Stupidly, Taro didn’t consider Hanako to be stupid.’

⁵Some people prefer the use of *-no koto* on the ECMed subject. For others, the choice is optional. See Kuno (1976) for some syntactic and semantic properties of *-no koto* in Japanese. Incidentally, Ewe, a Kwa language of West Africa has a similar word “matter, affair, word” used for subjects of experiencer verbs (Collins 1994).

- c. Taro-wa orokanimo **dare(-no-koto)-wo** baka da to-**mo** omowa-nakat-ta.
 Taro-Top stupidly Indet(-Gen-thing)-Acc stupid Cpl C-Q think-Neg-Pst
 ‘Stupidly, Taro didn’t consider anyone to be stupid.’
- d. * Taro-wa **dare(-no-koto)-wo_i** orokanimo *t_i* baka da to-**mo**
 Taro-Top Indet(-Gen-thing)-Acc stupidly stupid Cpl C-Q
 omowa-nakat-ta.
 think-Neg-Pst
 ‘Stupidly, Taro didn’t consider anyone to be stupid.’

As we have seen, Kishimoto (2001) claims that Indeterminate-Agreement is sensitive to an LF Case-checking configuration. However, the grammaticality of (19c) and (20c) indicates that his generalization is not correct. This is because under the LF Case checking theory, the accusative Case of the indeterminate in (20) is checked in [Spec, v^*P] at LF. Hence his theory wrongly predicts Indeterminate-Agreement to be blocked, since it does not satisfy his condition (13). The fact is, however, that Indeterminate-Agreement is blocked only when the ECMed indeterminate subject precedes the matrix adverbials.

(21) Raising-to-Object at LF under Kishimoto’s (2001) Theory

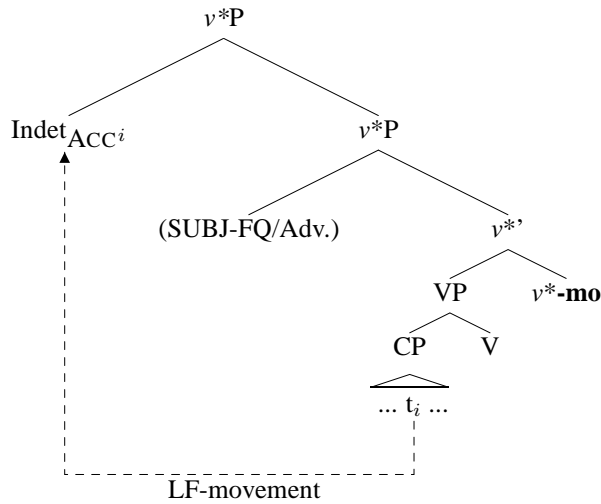

Now, in contrast, our hypothesis that Indeterminate-Agreement is subject to the condition (22) exactly explains the asymmetry of Indeterminate-Agreement in the RTO constructions.

(22) The head of the chain of the indeterminate must be in $cd(Q)$ at Transfer. (=15)

As shown below, Case is “assigned” in-situ from v^* via Agree and hence the indeterminate remains in-situ throughout the derivation.

(23) Case Assignment via Agree

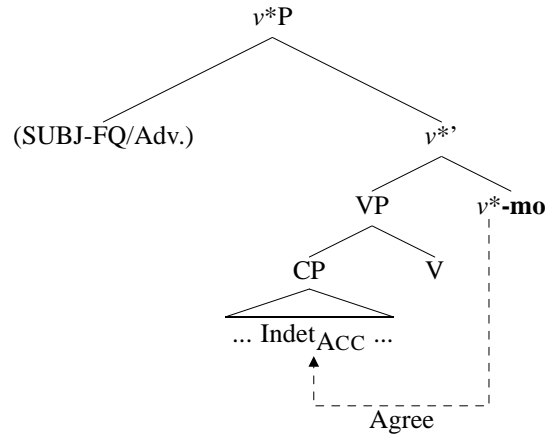

The facts in (19) and (20), along with our generalization (22), demonstrate that (i) syntactic raising into the matrix clause in RTO in Japanese is only optional and an ECMed DP can remain downstairs, and (ii) Case is assigned without displacement (i.e. via Agree rather than Spec-Head Agreement).

(24) provides further support to our generalization (15) that Indeterminate-Agreement is sensitive to the overt derivation, not LF configuration.

(24) Japanese:

- a. Taro-wa Hanako-ga **dare-wo** tatai-ta to-**mo** omowa-nakat-ta.
Taro-Top Hanako-Nom Indet-Acc hit-Pst C-Q think-Neg-Pst
'Taro didn't think that Hanako hit anyone.'
- b. *? **Dare-wo_i** Taro-wa Hanako-ga t_i tatai-ta to-**mo** omowa-nakat-ta.
Indet-Acc Taro-Nom Hanako-Top hit-Pst C-Q think-Neg-Pst
'Taro didn't think that Hanako hit anyone.'

Long-distance scrambling of the indeterminate to a position outside the $cd(Q)$ leads to ungrammaticality as shown in (24b). But it is to be noted that long-distance scrambling has been claimed to be totally reconstructed (Saito 1989, 1992). The ungrammaticality of (24b), therefore, indicates that Indeterminate-Agreement cannot be licensed by reconstruction. Therefore, Indeterminate-Agreement in RTO as well as long-distance scrambling of the indeterminates demonstrates that Kishimoto's LF theory of Indeterminate-Agreement is empirically problematic.

However, under our theory of Indeterminate-Agreement, it remains to be explained why there is such an asymmetry in (11), repeated below.

(25) Japanese:

Taroo-wa [**nani-*ga**/^{o.k.}-**wo** uta-e-mo] si-na-i.
Taro-Top Indet-Nom/-Acc sing-can-Q do-Neg-Prs

‘Taro cannot sing anything.’ slightly modified (Kishimoto 2001, 606)

This asymmetry is in fact expected under the phase theory developed in Chomsky (2000, 2001, 2004) and Nissenbaum (2001).

- (26) Phase Impenetrability Condition (PIC) Chomsky (2001)
 In phase α with head H, the domain of H is not accessible to operations outside α , only H and its edge are accessible to such operations.

If the PIC is on the right track, the only way for a goal element in the lower phase to be accessible to a higher probe is for the former to be moved to the edge of the lower phase. Following Chomsky (2004) (also Hiraiwa 2001, 2005, to appear), I assume that T does not probe until C is merged.

It follows from the PIC that the nominative object must be moved to the edge of the v^*P phase in order to have its uCase valued by the C-T. This has two consequences. First, the nominative object remains within v^*P and hence the Proper Binding Condition effects in (12) are accounted for as a failure for the v^*P to pied-pipe the nominative object.⁶ Second, since it is moved to the edge of v^*P and hence out of the c-command domain of the Q-particle *mo* attached to v^* , Indeterminate-Agreement fails.

- (27) Indeterminate Nominative Object Raised to the Edge of the v^*P Phase

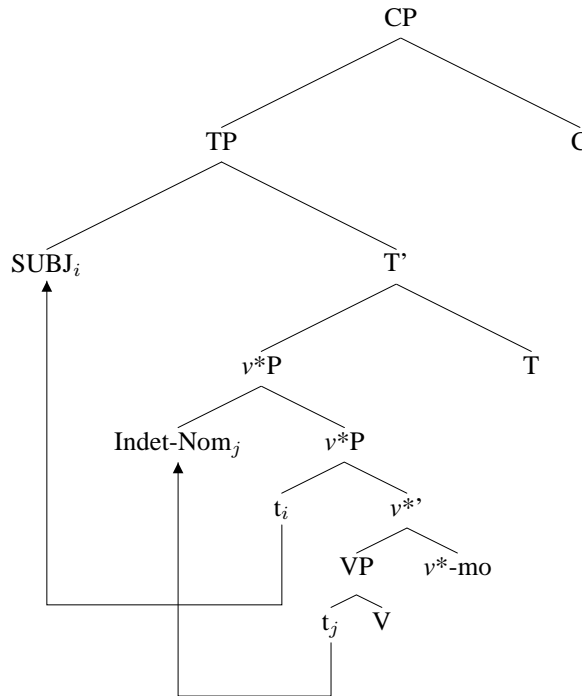

⁶Or in order to derive the order, the nominative object has to be scrambled out of the edge of v^*P , leaving a copy, which triggers PBC effects in (12). See Hiraiwa (2003) for extensive discussion of the PBC in Japanese.

3.2 More against Prolepsis/Control

One of the important consequences of the analysis of RTO/ECM presented above is that it provides us with solid evidence that the Prolepsis/Control/Major Object analyses (Saito 1985, Oka 1988, Hoji 1991) are not sufficient. The reason is, as we have seen, that the indeterminate ECMed subject can license Indeterminate-Agreement with the Q-particle attached to the embedded complementizer. This demonstrates that the accusative embedded subject must be within the c-command domain of the Q-particle attached to the complementizer *-to*. In contrast, this is totally unexpected under the prolepsis analysis, since the accusative element is base-generated in the matrix clause.

(28) further strengthens our conclusion. A true control construction cannot license Indeterminate-Agreement. This is expected under our generalization (15), since in (28b) the indeterminate is a matrix element and hence is not in $cd(Q)$ at any point of the derivation.

(28) Japanese:

- a. Taro-wa Hanako-ni_i [PRO_i MIT-ni iku koto]-wo susume-ta.
 Taro-Top Hanako-Dat MIT-Dat go C-Acc recommend-Pst
 ‘Taro recommended that Hanako go to MIT.’
- b. *? Taro-wa **dare-ni**_i [PRO_i MIT-ni iku koto]-**mo** susume-nakat-ta.
 Taro-Top Indet-Dat MIT-Dat go C-Q recommend-Neg-Pst
 ‘Taro did not recommend that anyone go to MIT.’

(28) in turn demonstrates that (i) the Indeterminate-Agreement diagnoses for the original position of an indeterminate NP and (ii) the RTO construction at least allows the derivation of (29b), in which an ECMed element remains downstairs via Agree.

It is important, however, to note that it still does not tell us whether the derivation of the RTO which involves overt raising into the matrix clause is “raising” (29a) or “prolepsis” (29b). Both derivations are logically possible.

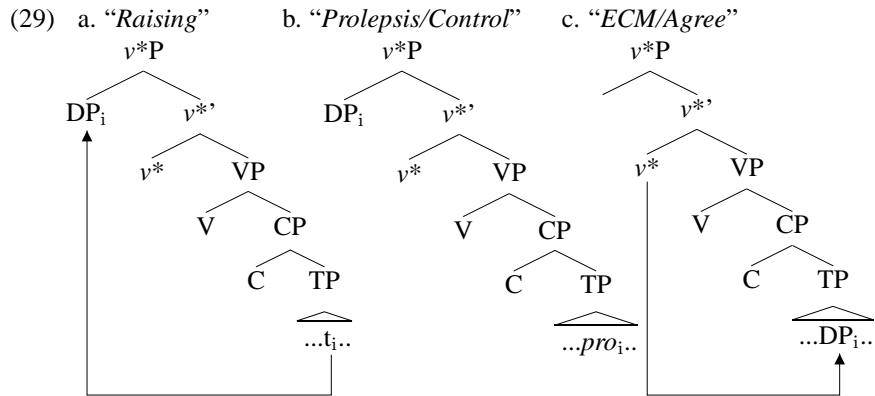

Thus in order to complete our claim for (29a) and (29c) over (29b), it is necessary to seek

other evidence. Such evidence comes from Proper Binding Condition (PBC) effects (cf. Saito 1989). RTO shows PBC effects, while genuine control constructions do not (cf. Kuno 1976).

(30) Japanese:

- a. Taro-wa Hanako-ni_j [PRO_j Boston-e iku-koto]-wo meiji-ta.
Taro-Top Hanako-Dat Boston-to go-C-Acc order-Pst
‘Taro ordered Hanako to go to Boston.’
- b. [_{CP} PRO_j Boston-e iku koto]-wo_i Taro-wa Hanako-ni_j t_i meiji-ta.
Boston-to go C-Acc Taro-Top Hanako-Dat order-Pst
‘Taro ordered Hanako to go to Boston.’

(31) Japanese:

- a. Taro-wa Hanako-wo_i (orokanimo) t_i baka da to omot-ta.
Taro-Top Hanako-Acc stupidly stupid Cpl.Prs C think-Pst
‘(Stupidly,) Taro considered Hanako to be stupid.’
- b. *? [_{CP} t_i baka da to_j] Taro-wa Hanako-wo_i (orokanimo) t_j omot-ta.
stupid Cpl.Prs C Taro-Top Hanako-Acc stupidly think-Pst
‘(Stupidly,) Taro considered Hanako to be stupid.’

In the genuine control constructions such as (30), fronting the embedded CP containing the PRO contree does not cause any problem, as shown in (30b). In the ECM/RTO construction (31), on the other hand, fronting the embedded CP containing the trace/copy of the ECMed subject results in ungrammaticality, as in (31b).

The robust contrast between (30b) and (31b) indicates not only that RTO is not a control construction but, more significantly, that the derivation of RTO never allows the control option.⁷

Summarizing the discussions so far, I have demonstrated, based on Indeterminate-Agreement, that RTO across a CP exists in Japanese and its derivation is uniformly “raising”, never “control”. The raising is optional in RTO and hence Case is not licensed in a structural Spec-Head configuration (see Chomsky 2000, Hiraiwa to appear, and Hiraiwa 2005).

3.3 Interim Summary

To recapitulate the conclusions so far, we have demonstrated the following.

- (32) a. Kishimoto’s (2001) theory of Indeterminate-Agreement is empirically insufficient. Instead, we have proposed a refined theory of Indeterminate-Agreement that is both empirically and conceptually adequate.
- b. Case assignment involves Agree (or similar mechanisms).
- c. The so-called Raising-to-Object/ECM constructions in Japanese cannot be an instance of Prolepsis/Control/Major Object.

⁷See Kuno (1976) for an idiom chunk test and other arguments for raising.

4 Phases and Successive Cyclic Raising

4.1 RTO, Phases, and the Edge

Now having established that RTO in Japanese is an (optional) raising construction, never a control construction, I propose a theory of RTO across a finite CP.

It has been observed that A-operations cannot apply beyond a finite CP boundary. Chomsky (1973) attributes this to Tensed-S Condition. As it is often noted, it can be also reduced to the “Chain Condition” on Case (Chomsky 1986), which prohibits double Case-marking. Recently, Chomsky (2000, 2001, 2004) has proposed the Phase Impenetrability Condition (PIC), repeated here again.

- (33) Phase Impenetrability Condition (PIC) Chomsky (2001)

In phase α with head H, the domain of H is not accessible to operations outside α , only H and its edge are accessible to such operations.

The PIC prevents a higher probe from accessing a goal in a lower phase, unless the latter is moved to the edge of the lower phase. So one expects an ECMed element in RTO to be first dislocated to the edge of the embedded CP clause, at which position it Agrees with v^* , deriving the Tensed-S Condition effects. I argue that this is in fact true. The derivation of RTO in Japanese consists of the following three operations:

- (34) The Derivation of RTO in Bruening (2001)

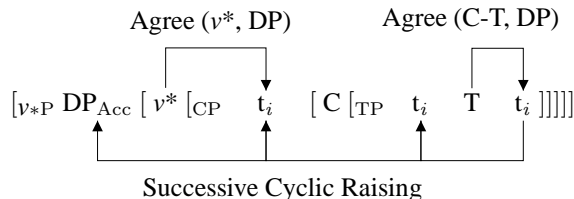

In this derivation, the embedded subject DP first Agrees with the embedded T and then undergoes dislocation to the edge of CP, where it again Agrees with v^* , having its uCase valued as Accusative.

Bruening (2001) has proposed exactly this derivation, assuming with Pesetsky and Torrego (2001) that valuation of Case (or deletion of uCase) is done at Spell-Out/Transfer; thus an element can in principle enter into multiple Agree relations as long as it is dislocated to the edge of a phase and escapes “inactivation” by Spell-Out/Transfer.⁸

Now let us return to Cuzco Quechua, repeated here as (35).

- (35) Cuzco Quechua (Lefebvre and Muysken 1988, 144, Claire. Lefebvre p.c.)

- a. Maryyacha numa-n **Xwancha-q(*-ta)** platanu ranti-na-n-ta.
 Maria want-3 Juan-Gen-Acc banana exchange-Nml-3-Acc
 ‘Maria wants Juan to buy bananas.’

⁸There is a nontrivial issue about the possibility that DP in Japanese also has two uCases like Cuzco Quechua. There is at least no morphological clue to this possibility.

- b. Maryyacha **Xwancha-q*(-ta)**_i numa-n t_i platanu ranti-na-n]-ta.
 Maria Juan-Gen-Acc want-3 banana exchange-Nml-3-Acc
 ‘Maria wants Juan to buy bananas.’

Cuzco Quechua provides us with direct evidence to choose the PIC over the Case Filter for RTO in Japanese and other languages; in Cuzco Quechua, the history of the syntactic derivation is morphologically recorded and visible in the form of “double Case-marking”. Significantly, as noted earlier, the ECMed embedded subject DP is doubly Case-marked Genitive (from the embedded C-T; see Hiraiwa 2001) as well as Accusative (from the matrix *v**). Furthermore, when the ECMed element is marked Accusative, it obligatorily moves into the matrix clause, in contrast with Japanese, whose raising in RTO is optional, as shown above.⁹

The “Multiple” Case-marking is crucially made possible by dislocation of the DP to the edge of the phase to escape valuation/inactivation. Thus under our theory the availability of RTO across a finite CP is predicted to be contingent on the availability of the “dislocation” operation to the edge.

- (36) The availability of “Hyper-Raising” correlates with the availability of the dislocation operation to the articulated CP-edge domain, which correlates with the availability of the articulated CP domain (cf. Rizzi 1997).

On this approach, the only significant differences between Japanese and Cuzco Quechua are that the morphological reflex of double Case-marking is suppressed in Japanese but not in Cuzco Quechua and that in the latter, raising into the matrix clause is forced but in the former it is just optional. The first issue will be addressed in this section and the latter –the raising asymmetry– is discussed in Section 5. In the remainder of this section, I will focus on the exact derivation –particularly, movement steps and positions– of Raising-to-Object.

One piece of evidence that an ECMed DP is dislocated to [Spec, CP], the edge position of the CP phase, comes from an interaction of Case-marking and modals.

- (37) Japanese:

- a. Taro-wa **Hanako-wa/wo/*ga** baka da-**naa** to omot-ta
 Taro-Top Hanako-Top/Acc/Nom stupid Cpl-M C think-Pst
 ‘Taro thought that Hanako was stupid.’
- b. Taro-wa **dare-wo/*ga** baka da-**naa** to-**mo** omowa-nak-ta.
 Taro-Top Indet-Acc/Nom stupid Cpl-M C-Q think-Neg-Pst
 ‘Taro did not think that anyone was stupid.’

(37a) and (37b) show that a sentence final modal *-naa* is incompatible with the nominative subject, whereas it is perfectly compatible with a topicalized subject or an ECMed accusative subject. I take this parallel between a topicalized DP and an ECMed DP to be an indication of structural parallelism.

A careful consideration of the derivation, however, brings to light one significant question. As we have proposed in (15), the Q-particle must c-command the head of the chain of the

⁹Multiple Case-Marking is rare but can still be found in some languages. See Bejar and Massam (1999) and McCreight (1988) for multiple Case-marking phenomena in Nieuwen and other languages.

indeterminate before Transfer. As I have argued, that was why the nominative object, being dislocated to the edge of v^*P , cannot license Indeterminate-Agreement in (27). Now, if we take this to be literally true with the CP edge, there will be a contradiction: the phase theory demands that the ECMed indeterminate subject be dislocated to the edge of CP, but how could it license Indeterminate-Agreement with the Q-particle attached to C in (38)?

(38) A Problem: ECMed Subject Raised to the Edge of the CP Phase

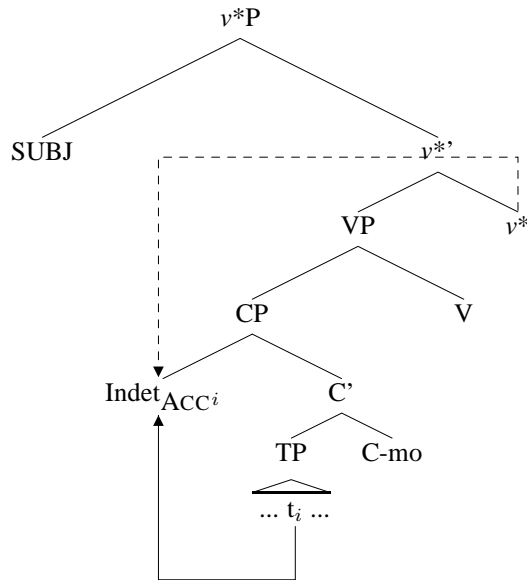

4.2 The Layered C Structure and v^* -Asp Relation

I propose that the key to solving this paradox is the articulated Left Periphery of CP (Rizzi 1997). Rizzi argues that the functional heads of the left periphery are richer than we have assumed (see also Hiraiwa 2005 for (39)).

(39) Split CP-TP Structure

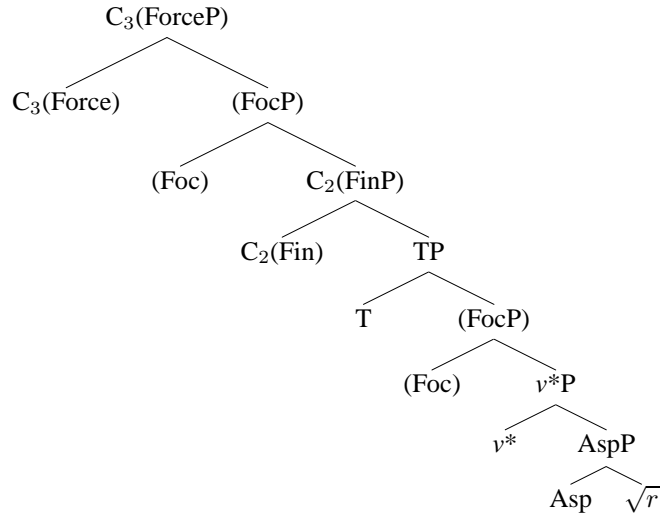

In this structure, the CP has a layered C structure: C_2 and C_3 . I propose that the Q-particle *-mo* attaches to C_3 , while the ECMed subject DP undergoes movement to the edge of C_2 P. In this configuration, the Q-particle still c-commands the indeterminate and hence Indeterminate-Agreement is licensed. I assume here that C_3 is not a strong phase head. I will turn to this soon in the next section.

(40) ECMed Subject Raised to the Edge of the C₂P Phase

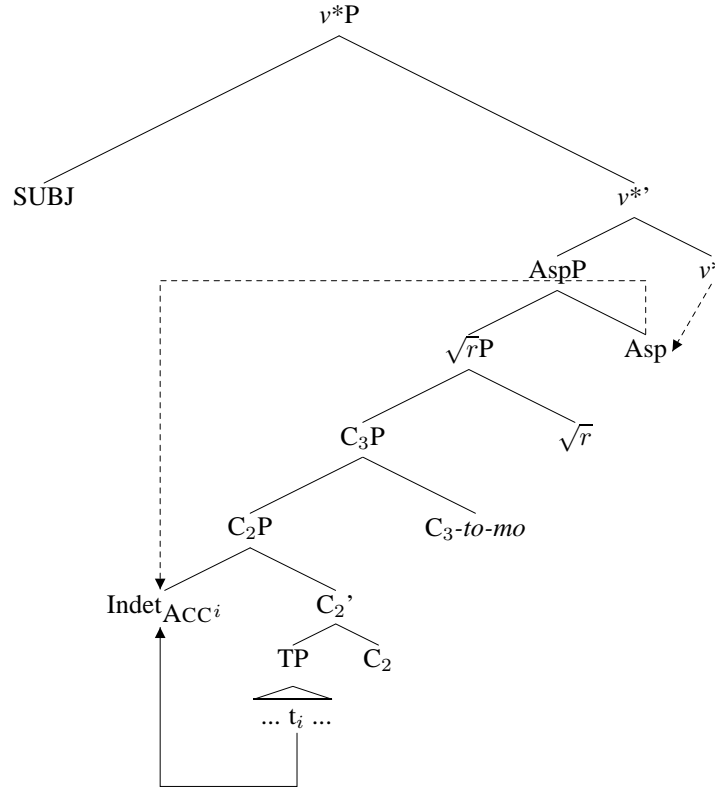

Now one prediction is that if an indeterminate is dislocated to the edge of the higher CP left periphery, Indeterminate-Agreement between the indeterminate and the Q-particle attached to the C₃ should be blocked. This is indeed borne out.

Long-distance scrambling has been known to target an \bar{A} -position –namely [Spec, CP] (Saito 1992, Miyagawa 1997). In Hiraiwa (2003), I have further refined this observation by showing that the element undergoing long-distance scrambling targets the left-most –“the edge”– position of the CP domain. Thus long-distance scrambled element must precede a topicalized element (41b) and (41c).

(41) Japanese:

- a. Taro-wa Hanako-ni [Jiro-ga katteni ringo-wo tabe-ta to]
 Taro-Top Hanako-Dat Jiro-Nom without.permission apple-Acc eat-Pst C
 iitsuke-ta.
 tell-Pst
 ‘Taro said to Hanako that Jiro ate some apples without permission.’
- b. ? **ringo-wo**_j Hanako-ni-wa_i Taro-ga t_i [Jiro-ga katteni t_j
 apple-Acc Hanako-Dat-Top Taro-Nom Jiro-Nom without.permission
 tabe-ta to] iitsuke-ta.
 eat-Pst C tell-Pst

‘To Hanako, Taro said that Jiro ate some apples without permission.’

- c. *? Hanako-ni-wa_i **ringo-wo**_j Taro-ga t_i [Jiro-ga t_j katteni
Hanako-Dat-Top apple-Acc Taro-Nom Jiro-Nom without.permission
tabe-ta to] iitsuke-ta.
eat-Pst C tell-Pst

‘To Hanako, Taro said that Jiro ate some apples without permission.’

Now consider long-distance scrambling of indeterminates.

(42) Japanese:

- a. * boku-wa [Taro-ga [Hanako-ga **dare-ni** at-ta to] sinjitei-ta to-**mo**]
I-Top Taro-Nom Hanako-Nom Indet-Dat meet-Pst C believe-Pst C-Q
omow-anakat-ta.
think-Neg-Pst
‘I didn’t think that Taro believes that Hanako met anyone.’
- b. * boku-wa [Taro-ga [**dare-ni**_i Hanako-ga t_i at-ta to] sinjitei-ta to-**mo**]
I-Top Taro-Nom Indet-Dat Hanako-Nom meet-Pst C believe-Pst C-Q
omow-anakat-ta.
think-Neg-Pst
‘I didn’t think that Taro believes that Hanako met anyone.’
- c. * boku-wa [**dare-ni**_i Taro-ga [Hanako-ga t_i at-ta to] sinjitei-ta
I-Top Indet-Dat Taro-Nom I Hanako-Nom meet-Pst C believe-Pst
to-**mo**] omow-anakat-ta.
C-Q think-Neg-Pst
‘I didn’t think that Taro believes that Hanako met anyone.’

These sentences have the Q-particle attached to the middle CP clause with the indeterminate originating in the lowest CP clause.

(42a) shows that the indeterminate is too far away from the Q-particle (separated by phase boundaries). (42b) indicates that Indeterminate-Agreement is still illicit if the indeterminate is moved to the edge of the lowest CP clause. The sentence is still bad since the Q-particle and the scrambled indeterminate are still separated by phase boundaries. Now the ungrammaticality of (42c) is quite important. It shows that the indeterminate cannot be licensed even if it is dislocated to the edge of the middle CP-edge position. Recall that there is no problem if the indeterminate is the subject of the middle clause as in (43).

(43) Japanese:

- ? boku-wa [**dare-ga** [Hanako-ga Taro-ni at-ta to] sinjitei-ta to-**mo**]
I-Top Indet-Nom Hanako-Nom Taro-Dat meet-Pst C believe-Pst C-Q
omow-anakat-ta.
think-Neg-Pst

‘I didn’t think that anyone believes that Hanako met Taro.’

The derivation below explains the ungrammaticality of (42c).

(44) Long-Distance Scrambling and Indeterminate-Agreement

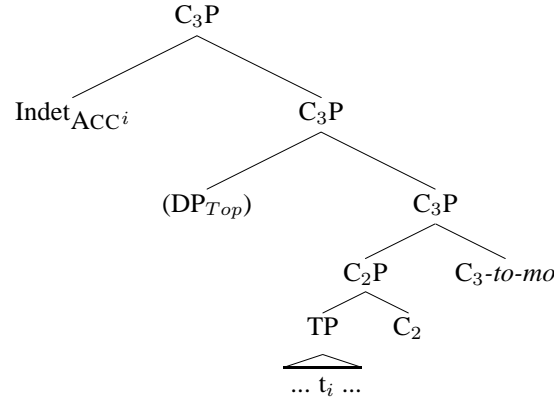

The indeterminate has been moved to the left edge of the second CP clause. Since, as evidenced by (41c), the landing position of the long-distance scrambled element is the left edge of the clause, it is [Spec, C₃P]. Because this position is outside the domain of the Q-particle attached to C₃, the Indeterminate-Agreement is illicit in (42c).

Now turning to the case where actual raising occurs, the same question arises: if RTO-movement targets the edge of v*P, it is expected that the Indeterminate-Agreement with the Q-particle attached to v* is blocked as it is in the nominative object constructions (11). The prediction is indeed true; the raised indeterminate, preceding the matrix subject floating quantifier (45a) or adverb (45b), cannot establish Indeterminate-Agreement with the Q-particle on v*.

(45) Japanese:

- a. * karera-wa **dare(-no-koto)-wo**_i zen-in t_i baka da to omoi-**mo** si-nakat-ta.
 they-Top Indet(-Gen-thing)-Acc all stupid Cpl C think-Q do-Neg-Pst
 ‘All of them didn’t consider anyone to be stupid.’
- b. * Taro-wa **dare(-no-koto)-wo**_i orokanimo t_i baka da to omoi-**mo**
 Taro-Top Indet(-Gen-thing)-Acc stupidly stupid Cpl C think-Q
 si-nakat-ta.
 do-Neg-Pst
 ‘Stupidly, Taro didn’t consider anyone to be stupid.’

Thus this is consistent with the standard assumption that Object Shift is a movement to [Spec, v*P].

(46) Raising-to-Object

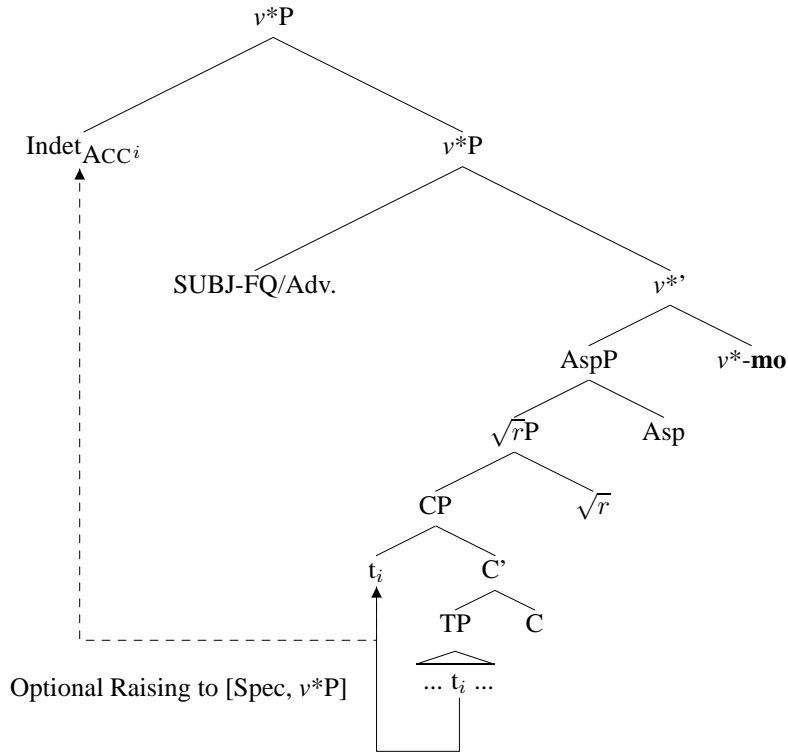

There is a case, however, that shows that the raised subject lands at a lower position. In (47a), the raised subject precedes the matrix dative argument. Significantly, in this case, Indeterminate-Agreement becomes licit as shown in (47b).

(47) Japanese:

- a. Taro-wa boku-no-koto-wo_i Hanako-ni t_i baka da to ii-mo si-nakat-ta.
 Taro-Top I-Gen-thing-Acc Hanako-Dat stupid Cpl C say-Q do-Neg-Pst
 ‘Taro didn’t even tell Hanako that I was stupid.’
- b. Taro-wa **dare-no-koto-wo**_i Hanako-ni t_i baka da to ii-**mo** si-nakat-ta.
 Taro-Top Indet-Gen-thing-Acc Hanako-Dat stupid Cpl C say-Q do-Neg-Pst
 ‘Taro didn’t tell Hanako that anyone was stupid.’

This suggests that the landing site of the raised subject in RTO is actually lower than the edge of v^*P . The most natural possibility is that raising targets the edge of AspP.

(48) Raising-to-Object (A new framework)

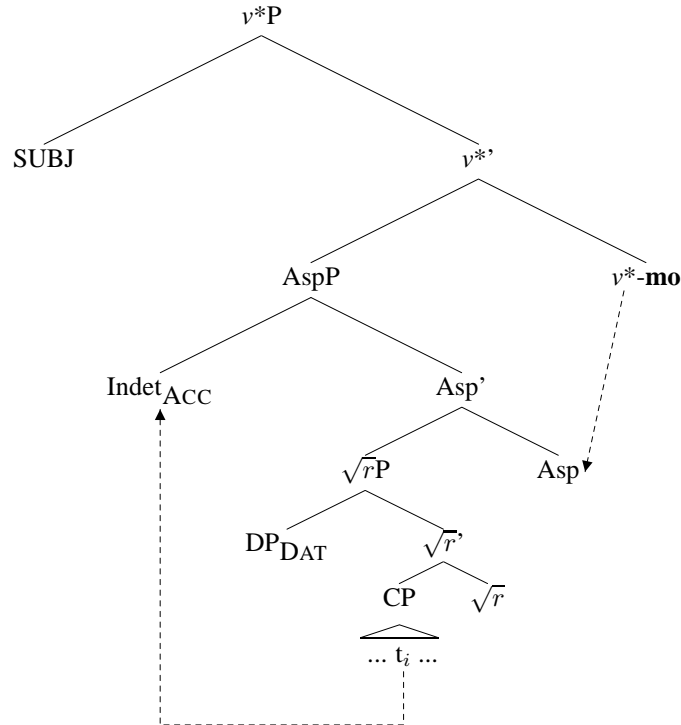

In (48), the raised indeterminate still remains in the $cd(Q)$ and hence can license Indeterminate-Agreement. In (46), on the other hand, the indeterminate has undergone displacement to the edge of v^*P , which precedes the positions for the external subject and the v^*P adverb.

The interesting question is why the raising-to-object operation is able to attract the goal to the edge of “VP” but not all the way up to the edge of v^*P . Chomsky (2005) has recently suggested an insightful solution to the problem of Koizumi’s Split VP Hypothesis (Koizumi 1993, 1995). Chomsky argues that just as T and C probe as a whole, v^* and Asp also probe as a unit and hence Asp attracts an A-chain element. Translating the idea into our terms, the theory of Case is summarized as follows.

- (49) a. Nominative Case is valued by C-T.
- b. Accusative Case is valued by v^* -Asp.

(50) Accusative Case Assignment as v^* -Asp Relation

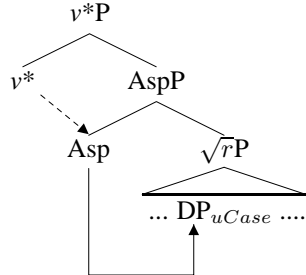

Chomsky further puts forward the parallelism and proposes that the EPP of C/v^* is passed down to T and V, respectively. If this is on the right track, object shift is expected to target the edge of “VP”, just as movement of the subject targets the edge of “TP”. This explains why in (48), the movement of the ECMed DP to the edge of $AspP$ is possible.

Drawing a further parallelism, the derivation of Raising-to-Object should involve the following steps, with raising to [Spec, v^*P] optional.

(51) Raising-to-Object (A new framework)

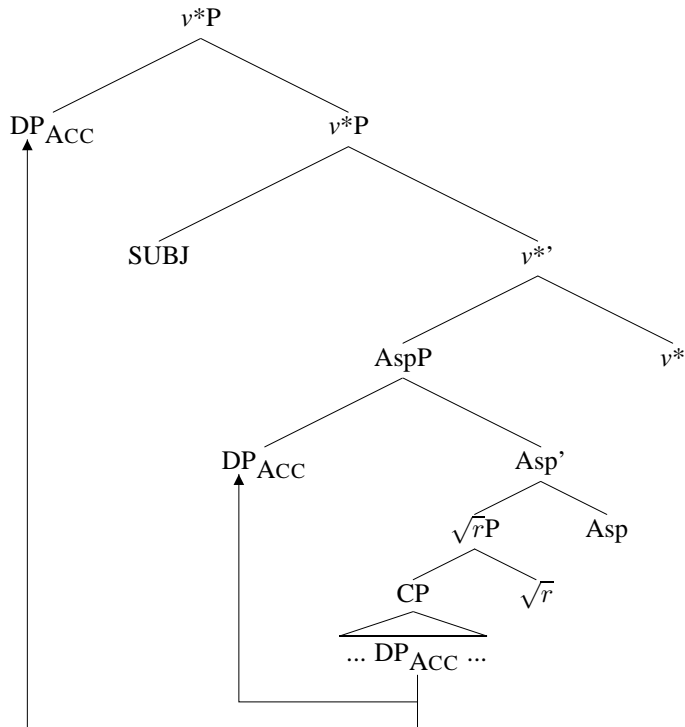

4.3 Optionality, Case, and Tense

The cartographic approach outlined above has shown that RTO/ECM in Japanese involves movement to the edge of C_2P . This explains the behaviors of indeterminates in RTO/ECM in Japanese.

The theory, however, has only partially answered a more fundamental question about the mechanisms of RTO/ECM. In Japanese, as in Cuzco Quechua and Modern Greek, RTO is optional. That is, the embedded subject is marked either Accusative or Nominative. Furthermore, Japanese apparently disallows “multiple Case-marking” unlike Cuzco Quechua. So what makes the RTO/ECM possible in terms of Case? In particular, why can a DP that originates within a lower finite clause Agree with a higher probe?

Interestingly, there is an asymmetry in tense between ECM/RTO and the nominative counterpart. At first glance, the predicate of the ECM/RTO clause can take either a present form or a past form. There is some speaker variation, but the past tense in (52b) is not totally unacceptable.

(52) Japanese:

- a. Boku-wa **Hanako-ga/wa** **kawai-i/kawaikat-ta** to omot-ta.
1Sg.-Top Hanako-Nom/Top pretty-Prs/pretty-Pst C think-Pst
'I thought that Hanako was pretty.'
- b. Boku-wa **Hanako(-no-koto)-wo** **kawai-i/[?]kawaikat-ta** to omot-ta.
1Sg.-Top Hanako(-Gen-matter)-Acc pretty-Prs/pretty-Pst C think-Pst
'I thought that Hanako was pretty.'

A careful investigation, however, soon reveals that it is not the case that tense is freely allowed in RTO/ECM complement clauses. The past tense on the embedded predicate is allowed only when the matrix tense is also past. If we change the tense of the matrix, the past tense downstairs becomes ungrammatical when ECM/RTO occurs, as shown in (53b).

(53) Japanese:

- a. Boku-wa **Hanako-ga/wa** **kawai-i/kawaikat-ta** to omo-u.
1Sg.-Top Hanako-Nom/Top pretty-Prs/pretty-Pst C think-Prs
'I think that Hanako was pretty.'
- b. Boku-wa **Hanako(-no-koto)-wo** **kawai-i/^{*?/??}kawaikat-ta** to omo-u.
1Sg.-Top Hanako(-Gen-matter)-Acc pretty-Prs/pretty-Pst C think-Prs
'I think that Hanako was pretty.'

Furthermore, it is worth pointing out that in (52), tense interpretations differ. In (52a), the past tense may refer to either the time identical to the matrix past tense or the time preceding the matrix time. In (52b), however, the past tense of the embedded predicate can only refer to the same time as the matrix past tense. Thus in (52b), there is no semantic difference in terms of tense.

The contrast becomes even clearer if we consider the tense patterns under Indeterminate-Agreement.

(54) Japanese:

- a. Boku-wa **dare-ga** **kawai-i/kawaikat-ta** to-mo omow-ana-i.
1Sg.-Top Indet-Nom pretty-Prs/pretty-Pst C think-Neg-Prs
'I don't think think that anyone was pretty.'
- b. Boku-wa **dare(-no-koto)-wo** **kawai-i/*kawaikat-ta** to-mo omow-ana-i.
1Sg.-Top Indet(-Gen-matter)-Acc pretty-Prs/pretty-Pst C think-Neg-Prs
'I don't think that anyone was pretty.'

Here, the past tense in the ECM clause is quite bad, when the matrix tense is present.

A similar, but not identical, situation has been observed for Modern Greek in Iatridou (1988/1993). She observes that when the embedded subject gets Accusative under ECM/RTO in Modern Greek, the embedded predicate cannot take a past form, while either present or past tense is allowed for non-RTO/ECM complements.

(55) Modern Greek (Iatridou 1988/1993, 176-7)

- a. vlepo ton Kosta na **tiganizi** psaria.
see D Kosta(Acc) NA fries fish
'I see Kostas fry fish.'
- b. * vlepo ton Kosta na **tiganize** psaria.
see D Kosta(Acc) NA fried fish
'(Lit.) I saw Kostas fried fish.'

(56) Modern Greek (Iatridou 1988/1993, 176-7)

- a. elpizo o Kostas na **tiganizi** psaria.
hope D Kosta(Nom) NA fries fish
'I hope Kostas fries fish.'
- b. elpizo o Kostas na **tiganise** psaria.
hope D Kosta(Nom) NA fried fish
'I hope Kostas fried fish.'

These indicate that Case in Japanese and Modern Greek is also sensitive to Tense, not only to Agreement (see Iatridou (1988/1993) for detailed discussions on Greek). Reconsidered in the present framework, I propose that the (un)availability of the past tense on the embedded predicates in (non-)ECM/RTO reduces to optional choice of Tense on C_{β} .

(57) Tense on T comes from C. (cf. Koster 2003)¹⁰

(58) Nominative is valued by $C_{+T/u\phi-T}$.

Irish provides visible evidence for the claim that C is tense-related. McCloskey (1979) shows that in embedded clauses in Irish, the complementizer changes its form depending on the Tense value.

¹⁰den Besten (1978, 1983) observes that C is the locus of tense operators. See also Koster (2003).

- (59) Irish (McCloskey 1979)
- a. Deir sé goN dtuigeann sé an scéal.
says he C understands he the story
'He says that he understands the story.'
 - b. Deir sé gurL thuig sé an scéal.
says he C understands he the story
'He says that he understood the story.'

Thus the optionality reduces to two derivations one with C_{+T} and the other C_{-T} . Raising out of the finite CP clause does not give rise to Case problems because of the asymmetry of tense feature distribution between these two types of C. When C_3 comes with [+T], the C_2 -T probe is capable of assigning nominative Case in its domain and hence no ECM/RTO takes place. If, on the other hand, C_3 comes with [-T], the C_2 -T system is unable to value uCase of a goal in its domain. Hence, the goal DP is dislocated to the edge of C_2 P and Agrees with the higher v -Asp probe. The proposed theory, if correct, makes a contribution to the PIC: what initially appears to violate the PIC does obey it through dislocation to the edge.

One remaining problem is how a higher probe can Agree with and assign a Case value to an element at the edge of C_2 P, crossing the C_3 P. If C_3 is a strong phase head, this should be impossible. I just suggest here that the distinction between strong and weak phase heads may be related to the presence/absence of Tense on C_3 . If it comes with Tense, it becomes a strong phase head, while if Tense is missing, it becomes a weak phase head. Another issue is why there are languages that do not allow raising out of CP clauses (e.g. English). I suggest that the difference may reduce to the availability of scrambling. In scrambling languages like Japanese and Cuzco Quechua, C can have EPP¹¹. This, as I argued, results in dislocation to the edge, which is saved from the PIC. A further cross-linguistic confirmation is necessary in future investigation (see also Ura 1994).

4.4 No “Super Long-Distance” Agree

The proposed phase-based theory of RTO predicts that RTO across a finite CP should be impossible across more than one CP phase boundary due to the PIC. For example, (60) is structurally ambiguous between (61a) and (61b), but the prediction is that the derivation of (60) is (61a) but not (61b).

- (60) Japanese:

Taro-wa **Hanako-wo** baka da to omow-arete-iru to omotte-iru.
Taro-Top Hanako-Acc stupid Cpl C think-Pass-Prs C think-Prs

'Taro believes Hanako to be believed to be stupid.'

- (61) a. $[v_{*P} v^* [CP_1 DP_{Acc,i} C [TP \dots [CP_2 t_i C [t_i \dots]]]]]$
- 

¹¹Miyagawa (2001) argues that A-scrambling in Japanese is driven by EPP. It seems natural to extend this view of EPP-scrambling to C, perhaps with a distinction of A/ \bar{A} -scrambling reduced to the edge/non-edge distinction.

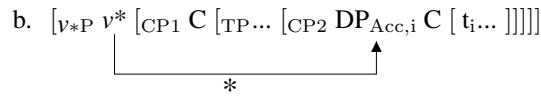

This prediction is in fact borne out. When the ECMed indeterminate is bound to the lower clause (62b), Agree (v^* , Indet) fails and accusative Case cannot be assigned, whereas Agree (v^* , Indet) is licit when it is bound to the higher embedded CP (62a).

(62) Japanese:

- a. Taro-wa $[_{CP1}$ **dare-wo/ga_i** $[_{CP2}$ t_i baka da to] omow-arete-iru to-**mo**]
 Taro-Top Indet-Acc/Nom stupid Cpl C think-Pass-Prs C-Q
 omottei-na-i.
 think-Neg-Prs
 ‘Taro thinks that no one is thought to be stupid.’
- b. Taro-wa $[_{CP1}$ $[_{CP2}$ **dare-*wo*/ga_i** baka da to-**mo**] omow-aretei-na-i to]
 Taro-Top Indet-Acc/Nom stupid Cpl C-Q think-Pass-Neg-Prs C
 omotte-iru.
 think-Prs
 ‘Taro thinks that it is thought that no one is stupid.’

5 Varieties of Raising

If our syntactic generalization of Indeterminate-Agreement is correct, then Indeterminate-Agreement provides us with a solid tool to detect overt raising out of a domain headed by the Q-particle. In this final section, I examine varieties of raising constructions through applications of Indeterminate-Agreement.

5.1 Raising Types

5.1.1 Raising-to-Subject

I have claimed that an indeterminate cannot be moved out of $cd(Q)$. The same is true of Raising-to-Subject (RTS; (63)) as well, as shown by Indeterminate-Agreement in (64). When the raised subject precedes the matrix experiencer argument (64a), Indeterminate-Agreement is blocked, while it is licit when the raised indeterminate subject follows the experiencer (64b).

(63) Japanese: Raising-to-Subject

- a. **Hanako-ga_i** minna-ni $[\ t_i \ wagamama-ni]$ omow-are-ta.
 Hanako-Nom everyone-by selfish-Inf think-Pass-Pst
 ‘Hanako seemed to everyone to be selfish.’
- b. Minna-ni [**Hanako-ga** wagamama-ni] omow-are-ta.
 everyone-by Hanako-Nom selfish-Inf think-Pass-Pst
 ‘Hanako seemed to everyone to be selfish.’

(64) Japanese: Raising-to-Subject and Indeterminate-Agreement

- a. * **Dare-ga**_i minna-ni [t_i wagamama-ni]-**mo** omow-aretei-na-i.
Indet-Nom everyone-by selfish-Inf-Q think-Pass-Neg-Prs
'No one seemed to everyone to be selfish.'
- b. Minna-ni [**dare-ga** wagamama-ni]-**mo** omow-aretei-na-i.
everyone-by Indet-Nom selfish-Inf-Q think-Pass-Neg-Prs
'No one seems to everyone to be selfish.'

One might wonder what happens to the EPP of T when raising-to-subject does not occur above. Whatever the explanation is, however, the facts seem to indicate that EPP is optional for unaccusative/passive predicates in Japanese. Kuroda (1978) points out that Japanese has a kind of null expletive construction in which no overt counterpart is found.

(65) Japanese:

Shigurete-ki-ta.
shower-start-Pst

'It started to shower.' (Kuroda 1978)

The following impersonal passive example further shows that the sentence is fine even if there is no subject.

(66) Japanese:

Kaigi-de(-wa) [department-no samazamana mondai]-nituite hanasiaw-are-ta.
meeting-at(-Top) department-Gen various problems-about talk-Pass-Pst

'(Lit.) It was discussed about various problems of the department at the meeting.'

5.1.2 Possessor Raising

It should be noted that Indeterminate-Agreement is blocked in the Possessor Raising constructions.¹² In (67a), the inalienable possessor is marked Genitive and it forms a constituent with the possessee. Hence the adverb cannot intervene. In (67b), on the other hand, the inalienable possessor is marked Accusative and it is raised out of the host possessee DP. This is indicated by the fact that it can precede the adverb.

(67) Japanese: Possessor Raising

- a. Taro-wa [DP **Hanako-no** (*tsuyoku) te]-wo/-mo tatai-ta.
Taro-Top Hanako-Gen hard hand-Acc/-also hit-Pst
'Taro hit Hanako's hand (hard).'

¹²Possessor Raising has been assumed –wrongly in my view– to be missing in Japanese because of the so-called *Double-o Constraint*. See Kuroda (1988, 1992) and in particular Hiraiwa (2002a) for full discussions on the nature of the constraint and a discovery of the existence of Possessor Raising in Japanese.

- b. Taro-wa **Hanako-wo**_i (tsuyoku) [_{DP} t_i te]^{-??} wo/-mo tatai-ta.
 Taro-Top Hanako-Acc hard hand-Acc/-also hit-Pst
 ‘Taro hit Hanako’s hand (hard).’

Now Indeterminate-Agreement reveals that this movement out of the DP –“possessor raising”– is obligatory when the possessor is marked Accusative. In other words, the possessor cannot Agree with *v** from within the edge of the DP.

(68) Japanese:

- a. Taro-wa [_{DP} **dare-no** te]-**mo** tataka-nakat-ta.
 Taro-Top Indet-Gen hand-Q hit-Neg-Pst
 ‘Taro did not hit anyone’s hand.’
- b. * Taro-wa **dare-wo**_i [_{DP} t_i te]-**mo** tataka-nakat-ta.
 Taro-Top Indet-Acc hand-Q hit-Neg-Pst
 ‘Taro did not hit anyone’s hand.’

5.1.3 Light-Verb Constructions

The same is observed for the Light-Verb constructions (Kageyama 1993, Saito and Hoshi 2000). In the Light-Verb construction (69), *v** Agrees with the genitive DP in the specifier of the verbal noun DP and the former DP moves out of the latter DP.

(69) Japanese:

- a. Taro-wa [_{VN} **Navajo-no** kenkyuu]-wo/-* \emptyset si-ta.
 Taro-Top Navajo-Gen study-Acc do-Pst
 ‘Taro did a study on Navajo (as well).’
- b. Taro-wa **Navajo-wo** [_{VN} t_i kenkyuu]^{-??} wo/-mo/ \emptyset si-ta.
 Taro-Top Navajo-Acc study-Acc/-also/ \emptyset do-Pst
 ‘Taro did a study on Navajo (as well).’

Again, when the indeterminate direct object of the verbal noun is marked Accusative, Indeterminate-Agreement shows that it is obligatorily moved out of *cd*(Q) (see (70a) and (70b)). On the other hand, (70c) indicates that Indeterminate-Agreement is licensed if the Q-particle is attached with the light verb *-sur*, which is supposed to be *v**.

(70) Japanese:

- a. Taro-wa [_{VN} **nani-go-no** kenkyuu]-**mo** si-nakat-ta.
 Taro-Top Indet-language-Gen study-Q do-Neg-Pst
 ‘Taro did not do a study of any language.’
- b. * Taro-wa **nani-go-wo**_i [_{VN} t_i kenkyuu]-**mo** si-nakat-ta.
 Taro-Top Indet-language-Acc study-Q do-Neg-Pst
 ‘Taro did not do a study of any language.’
- c. Taro-wa **nani-go-wo**_i [_{VN} t_i kenkyuu]-**si-mo** si-nakat-ta.
 Taro-Top Indet-language-Acc study-do-Q do-Neg-Pst
 ‘Taro did not do a study of any language.’

5.1.4 CP-Restructuring

Finally, let us consider the CP-restructuring constructions discussed in Kuno (2002). As shown in (71), the object of the verb ‘speak’ can be assigned regular accusative Case or nominative Case.

(71) Japanese:

- a. Taro-wa [_{CP} **nihongo-wo** hanas-u koto]-ga/sae deki-ru.
Taro-Top Japanese-Acc speak-Inf C-Nom/even can-Prs
‘Taro can speak Japanese.’
- b. Taro-wa **nihongo-ga_i** [_{CP} t_i hanas-u koto]-ga/sae deki-ru.
Taro-Top Japanese-Nom speak-Inf C-Nom/even can-Prs
‘Taro can (even) speak Japanese.’ (Kuno 2002)

Since nominative Case cannot be assigned to the object by the verb as shown in (72), the nominative Case in (71) comes from the higher matrix T.¹³

(72) Japanese:

- Taro-wa **nihongo-wo/*ga** hanas-u.
Taro-Top Japanese-Acc/Nom speak-Prs
‘Taro speaks Japanese.’

Now significantly, (73) indicates that Indeterminate-Agreement is licit with accusative whereas it is illicit with nominative.

(73) Japanese:

- a. Taro-wa [**nani-go-wo** hanas-u koto]-**mo** deki-na-i.
Taro-Top Indet-foreign.language-Acc speak-Inf C-Q can-Neg-Prs
‘Taro cannot speak any foreign language.’
- b. * Taro-wa **nani-go-ga_i** [t_i hanas-u koto]-**mo** deki-na-i.
Taro-Top Indet-foreign.language-Nom speak-Inf C-Q can-Neg-Prs
‘Taro cannot speak any foreign language.’

5.2 ϕ -over- ϕ

We have two distinct cases of raising: optional raising (RTO/RTS) on the one hand, and forced raising (poss-raising, light-verb constructions, CP-restructuring) on the other. The important question is what principle determines the optionality of raising. Syntactic raising in fact seems to be forced in Object Possessor-Raising cross-linguistically. (cf. Baker 1988, Massam 1985).

I propose the following descriptive generalization.

¹³Kuno (2002) independently concludes, based on intonation breaks, that the nominative DP in (71) is obligatorily raised into the matrix clause.

- (74) The α -over- α Generalization
 Agree (γ, α) always triggers Move (γ, α), if α is dominated by β , which also contains a feature matching with the probe γ .

- (75) ϕ -over- ϕ Generalization

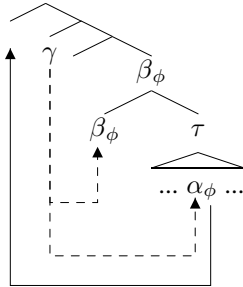

(74) says that raising of α out of β is forced in the “A-over-A configuration” (cf. Chomsky 1964) like (75), where a probe $-\phi$ -features of δ - enters into an Agree relation with a goal $-\phi$ -features of α - in [Spec, β], where the head of β also has matching ϕ -features.

Finally, it should be recalled that there is a significant asymmetry between Japanese and Cuzco Quechua: raising in RTO is optional in the former but forced in the latter (see Section 3–5). This asymmetry is precisely predicted under the ϕ -over- ϕ generalization (74); the embedded CP out of which RTO occurs is a nominalized clause in Cuzco Quechua and it is a non-nominalized clause in Japanese. The complementizer is nominalized and the whole CP in Cuzco Quechua is Case-marked accusative by the matrix verb, thereby triggering the ϕ -over- ϕ effects. In Japanese, on the other hand, the complementizer *-to* is non-nominalized and the CP is Case-less. Therefore, raising is not forced in Agree (v^* , DP). A theoretical elucidation of the generalization (74), however, remains to be investigated in the future.

6 Concluding Remarks

To summarize the paper, I have demonstrated, contra Kishimoto (2001), that Indeterminate-Agreement is subject to strict c-command and that the valuation of structural accusative Case is a property of action at a distance Agree (v^* -Asp, G). One of the important consequences of our conclusion is that it reveals that Raising-to-Object in Japanese involves Agree, not prolepsis or Control (Saito 1985, Hoji 1991, Takano 2003 etc.). I have further argued that syntactic raising of the ECMed subject to the matrix clause is optional and when the raising takes place, it is a two-step process: first, it is raised to the edge of “VP” and then, if necessary, it moves to the edge of v^* P. The derivation adds further support for the claim that Case assignment is a property of a phase head *c* plus a tense/aspect head: nominative Case C-T and v^* -Aspect, respectively, and that A-movement targets the positions lower than the phase heads (C/ v^*).

References

- Baker, Mark. 1988. *Incorporation: A theory of grammatical function changing*. Chicago: University of Chicago Press.

- Bejar, Suzana, and Diane Massam. 1999. Multiple case checking. *Syntax* 2(2):65–79.
- den Besten, Hans. 1978. Auxiliary deletions and the interplay between local deletive rules and filters. Paper presented at the GLOW Colloquium, Amsterdam.
- den Besten, Hans. 1983. On the interaction of root transformations and lexical deletive rules. In *On the formal syntax of the Westgermania. papers from the “3rd Groningen Grammar Talk” Groningen, January 1981*, ed. Werner Abraham, 47–131. Amsterdam/Philadelphia: John Benjamins.
- Bruening, Benjamin. 2001. *Syntax at the Edge: Cross-Clausal Phenomena and the Syntax of Passamaquoddy*. Ph.D. dissertation, MIT.
- Chomsky, Noam. 1964. *Current issues in linguistic theory*. The Hague, Mouton.
- Chomsky, Noam. 1973. Conditions on transformations. In *A festschrift for Morris Halle*, ed. S.R. Anders et. al, 232–286. New York: Holt, Reinhart and Winston.
- Chomsky, Noam. 1986. *Knowledge of language: its nature, origin, and use*. Praeger: New York.
- Chomsky, Noam. 1993. The minimalist program for linguistic theory. In *The view from Building 20: Essays in linguistics in honor of Sylvain Bromberger*, ed. Ken Hale and Samuel J. Keyser, 1–52. Cambridge, MA.: MIT Press.
- Chomsky, Noam. 1995. *The minimalist program*. Cambridge, MA.: MIT Press.
- Chomsky, Noam. 2000. Minimalist inquiries. In *Step by step: Essays on minimalism in honor of Howard Lasnik*, ed. R. Martin et. al, 89–155. Cambridge, MA.: MIT Press.
- Chomsky, Noam. 2001. Derivation by phase. In *Ken Hale: A life in language*, ed. Michael Kenstowicz, 1–52. Cambridge, MA.: MIT Press.
- Chomsky, Noam. 2004. Beyond explanatory adequacy. In *Structures and beyond: The cartography of syntactic structures*, ed. A. Belletti, 104–131. New York: Oxford University Press.
- Chomsky, Noam. 2005. On phases. Ms., MIT (To appear in a Festschrift for J.-R. Vergnaud).
- Collins, Chris. 1994. The factive construction in Kwa. In *Travaux de recherche sur le créole haïtien*, ed. Claire Lefebvre, 31–65. Monreal: Groupe de recherche sur le créole haïtien, Département de linguistique, Université du Québec à Montréal.
- Hagstrom, Paul. 1998. *Decomposing Questions*. Ph.D. dissertation, MIT.
- Hiraiwa, Ken. 2001. On nominative-genitive conversion. In *A few from Building E39*, ed. Elena Guerzoni and Ora Matushansky, MIT Working Papers in Linguistics 39, 65–123. Cambridge, MA: MITWPL.

- Hiraiwa, Ken. 2002a. Facets of Case: On the nature of the Double-O Constraint. In *The proceedings of the 3rd Tokyo Psycholinguistics Conference (TCP 2002)*, ed. Yukio Otsu, 139–163. Tokyo: Hituzi Publishers.
- Hiraiwa, Ken. 2002b. Indeterminate-agreement and varieties of raising. Ms., MIT (A paper accepted for WCCFL 21 at UCSC).
- Hiraiwa, Ken. 2003. Movement and derivation: Eliminating the PBC. In *The proceedings of the penn linguistic colloquium 26*. Philadelphia, PA: UPenn Working Papers in Linguistics.
- Hiraiwa, Ken. 2005. *Dimensions of symmetry in syntax: agreement and clausal architecture*. Unpublished Ph.D. dissertation, MIT.
- Hiraiwa, Ken. to appear. Dimensions of agreement. In *Complex agreement systems*, ed. Cedric Boeckx. New York: Oxford University Press.
- Hoji, Hajime. 1991. Raising-to-object, ECM and the major object in Japanese. A handout presented at Japanese Syntax Workshop at University of Rochester.
- Iatridou, Sabine. 1988/1993. On nominative case assignment and a few related things. In *Papers on case and agreement ii: Mit working papers in linguistics #19*, ed. Collin Phillips, 175–196. Cambridge, MA: MITWPL.
- Kageyama, Taro. 1993. *Bunpoo to gokeisei*. Tokyo: Hituzi.
- Kishimoto, Hideki. 2001. Binding of indeterminate pronouns and clause structure in Japanese. *Linguistic Inquiry* 32(4):597–633.
- Koizumi, Masatoshi. 1993. Object agreement phrases and the split vp hypothesis. In *MIT working papers in linguistics #18: Papers in case and agreement I*, 99–148. Cambridge, MA.: MITWPL.
- Koizumi, Masatoshi. 1995. *Phrase Structure in Minimalist Syntax*. Ph.D. dissertation, MIT.
- Koster, Jan. 2003. All languages are tense second. In *Germania et Alia: A linguistic webschrift for Hans den Besten*, ed. Jan Koster and Henk van Riemsdij, (<http://odur.let.rug.nl/koster/DenBesten/contents.htm>). Groningen: University of Groningen.
- Kuno, Susumu. 1972. On subject-raising in Japanese. *Papers in Japanese Linguistics* 1(1):24–51.
- Kuno, Susumu. 1976. Subject raising. In *Syntax and semantics 5: Japanese generative grammar*, ed. Masayoshi Shibatani, 17–49. NY: Academic Press.
- Kuno, Susumu. 2002. NPI licensing, ga/o alternation, verb raising and scrambling. In *The proceedings of the 10th Japanese and Korean Linguistics*, ed. Noriko Akatsuka et. al, 465–480. Chicago, IL: CSLI/University of Chicago.

- Kuroda, S.-Y. 1965. *Generative Grammatical Studies in the Japanese Language*. Ph.D. dissertation, MIT.
- Kuroda, S.-Y. 1978. Case-marking, canonical sentence patterns, and counter-equivalents in Japanese. In *Japanese syntax and semantics*, ed. S.-Y. Kuroda, 222–239. Dordrecht: Kluwer Academic Publishers.
- Kuroda, S.-Y. 1988. Whether we agree or not: a comparative syntax of English and Japanese. *Linguisticae Investigationes* 12:1–47.
- Kuroda, S.-Y. 1992. *Japanese syntax and semantics: Collected papers*. Dordrecht: Kluwer Academic Publishers.
- Lasnik, Howard. 1999. Chains of arguments. In *Working minimalism*, ed. Samuel D. Epstein and Norbert Hornstein, 189–215. Cambridge, MA.: MIT Press.
- Lefebvre, Claire, and Pieter Muysken. 1988. *Mixed categories: Nominalization in Quechua*. Dordrecht: Kluwer Academic Publishers.
- Massam, Diane. 1985. *Case theory and the projection principle*. Ph.D. dissertation, MIT.
- McCloskey, James. 1979. *Transformational syntax and model-theoretic semantics: A case study in Modern Irish*. Dordrecht: Reidel.
- McCreight, Katherine L. 1988. *Multiple Case Assignment*. Ph.D. dissertation, MIT.
- McGloin, Naomi. 1976. Negation. In *Syntax and semantics 5: Japanese generative grammar*, ed. Masayoshi Shibatani, 371–419. New York: Academic Press.
- Miyagawa, Shigeru. 1997. Against optional scrambling. *Linguistic Inquiry* 28:1–25.
- Miyagawa, Shigeru. 2001. EPP, scrambling and wh-in-situ. In *Ken Hale: A life in language*, ed. Michael Kenstowicz, 293–338. Cambridge, MA.: MIT Press.
- Muraki, Masatake. 1978. The *sika-nai* construction and predicate restructuring. In *Problems in Japanese syntax and semantics*, ed. Jhon Hinds and Irwin Howard, 155–177. Tokyo: Kaitakusha.
- Nishigauchi, Taisuke. 1990. *Quantification in the theory of grammar*. Dordrecht: Kluwer Academic Publishers.
- Nissenbaum, Jon. 2001. *The Investigations of Covert Phrasal Movement*. Ph.D. dissertation, MIT.
- Oka, Toshifusa. 1988. Abstract case and empty pronouns. *Tsukuba English Studies* 7:187–227.
- Pesetsky, David, and Ester Torrego. 2001. T-to-C movement: causes and consequences. In *Ken Hale: A life in language*, ed. Michael Kenstowicz, 355–426. Cambridge, MA.: MIT Press.

- Postal, Paul. 1974. *On raising*. Cambridge, MA.: MIT Press.
- Rizzi, Luigi. 1997. The fine structure of the left periphery. In *Elements of grammar: Handbook in generative syntax*, ed. Liliane Haegeman, 281–337. Dordrecht: Kluwer Academic Publishers.
- Rosenbaum, Peter S. 1967. *The grammar of English predicate complement constructions*. Cambridge, MA.: MIT Press.
- Saito, Mamoru. 1985. *Some Asymmetries in Japanese and their Theoretical Implications*. Ph.D. dissertation, MIT.
- Saito, Mamoru. 1989. Scrambling as semantically vacuous a-movement. In *Alternative conceptions of phrase structure*, ed. M. Baltin and A. Kroch, 182–200. Chicago, IL.: University of Chicago Press.
- Saito, Mamoru. 1992. Long distance scrambling in Japanese. *Journal of East Asian Linguistics* 1:69–118.
- Saito, Mamoru, and Hiroto Hoshi. 2000. Japanese light verb construction and the minimalist program. In *Step by step: In honor of Howard Lasnik*, ed. Roger Martin et. al, 261–296. Cambridge, MA.: MIT Press.
- Sakai, Hiromu. 1998. Raising asymmetries and improper movement. In *The proceedings of the 7th Japanese and Korean*, 481–497. Stanford, CA.: CSLI.
- Takahashi, Daiko. 2002. Determiner raising and scope shift. *Linguistic Inquiry* 33(4):575–615.
- Takano, Yuji. 2003. Nominative objects in Japanese complex predicate constructions: A prolepsis analysis. *Natural Language and Linguistic Theory* 21:779–834.
- Ura, Hiroyuki. 1994. *Varieties of raising and the feature-based bare phrase structure theory*. MIT Occasional Papers in Linguistics 4. Cambridge, MA: MITWPL.

Ken Hiraiwa
 hiraiwa@alum.mit.edu
<http://alum.mit.edu/www/hiraiwa>